

NOMBRE

**COMEDERO POLLITOS 2 kg**

REFERENCIA

**30075**

## CARACTERÍSTICAS DE PRODUCTO

MATERIAL

POLIPROPILENO

COLOR

VERDE-BLANCO

PESO

0,174 kg

TIPO DE CIERRE

GIRO

ACCESORIOS

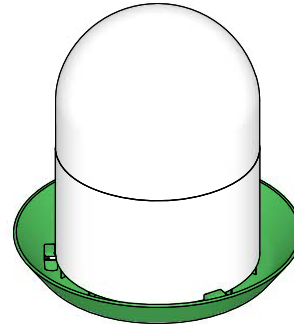

CROQUIS

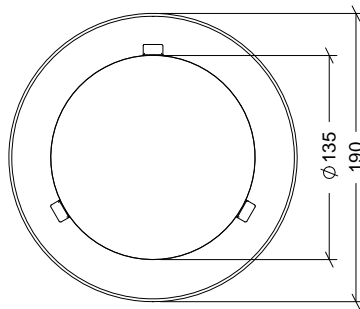
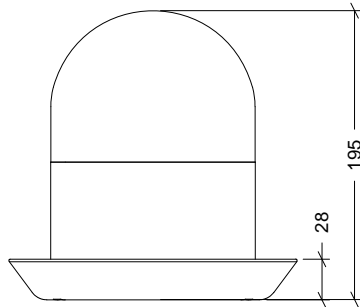

1

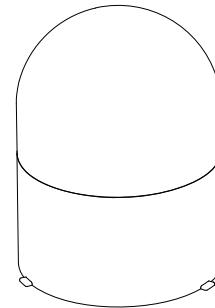

1	BIDÓN
2	PLATO

2

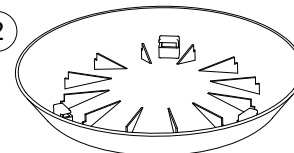

## CARACTERÍSTICAS DE EMBALAJE

TIPO DE PACKING

CAJA

UNIDADES/CAJA

10 Unidades

DIMENSIONES CAJA

420×290×300 mm

PESO CAJA

2,111 kg

VOLUMEN CAJA

0,037 m<sup>3</sup>

PALET EUROPEO

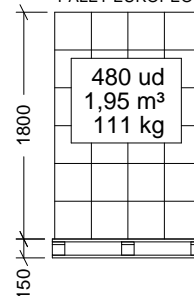

PALET AMERICANO

